



**Henan Qianjin Heavy Industry Casting and Forging Co. LTD**





# Henan Qianjin Heavy Industry Casting and Forging Co. LTD



Henan Qianjin





# Henan Qianjin Heavy Industry Casting and Forging Co. LTD



Henan Qianjin Steel Foundry Company is located in Hongzhou Industry Park of Hui county in Henan. It is next to the Taihang Mountains which is known as Chinese strength of character in the south, next to Bali Gou scenic which is one of the most beautiful scenic in Asia in the east. **Qianjin Group has the total area of about 600 acres, the total assets of 650 million yuan, and more than 680 employees. The annual capacity is about 100,000 tons of steel castings.** The environment around is elegant and the transport is convenient. **Henan Qianjin Steel Foundry Company is one of the largest private casting enterprises in Asia and has achieved IOS9001 quality management system certification, China Classification Society Certification (CCS), and France BV certification.**



# Henan Qianjin Heavy Industry Casting and Forging Co. LTD



Qianjin Group is fully equipped with advanced production equipment and testing equipment. The **driving** has a single maximum capacity of **260 tons**. Qianjin Group is also equipped with **three electric arc furnace** of **5 tons**, **30 tons** and **80 tons**, **20 T/H resin sand line**, **three CNC high-temperature heat treatment furnaces** of **12m\*7m\*5m**, **8m\*4m\*3.5m** and **8m\*4m\*3.3m**, one set of **EAF dust removal system** of **30,000 square meters**, and **machining equipment**, such as **vertical lathe** of **8m**, **6.3m**, and **5m**, and **220 boring-milling machine**. Qianjin Group has a independent testing center which is equipped with **chemical laboratory**, **direct-reading spectrometer**, **60 tons tensile testing machine**, **impact testing machine**, **ultrasonic flaw detector**, **Leeb hardness tester**, **metallurgical microscope** and so on.



# Henan Qianjin Heavy Industry Casting and Forging Co. LTD



With **40 years development** in steel foundry industry, our company now has a **first-class science and technology development centers** and experienced craftsmen team. Qianjin Group specializes in manufacturing **extra large steel casting products**. The production process adopts joint casting. **One joint tapping is up to 400 tons** and the unit weight of casting product can reach **300 tons**. The casting products can be widely applied to mining, shipbuilding, forging, metallurgy, engineering machinery, road & bridge engineering, water conservancy project, nuclear power, etc. Qianjin Group provide the national key equipment manufacturing with a variety of high quality and multi-standard carbon steel and alloy steel castings.



**Henan Qianjin Heavy Industry Casting and Forging Co. LTD**

## **5 ton electric arc furnace**





**Henan Qianjin Heavy Industry Casting and Forging Co. LTD**

---

## **30 ton electric arc furnace**





**Henan Qianjin Heavy Industry Casting and Forging Co. LTD**

## **80 tons high power electric arc furnace**





**Henan Qianjin Heavy Industry Casting and Forging Co. LTD**

## **120 ton electric arc furnace**





**Henan Qianjin Heavy Industry Casting and Forging Co. LTD**

**Dust removal equipment for electric furnace**





**Henan Qianjin Heavy Industry Casting and Forging Co. LTD**

## **260 ton crane**





**Henan Qianjin Heavy Industry Casting and Forging Co. LTD**

## **3 CNC natural gas heat treatment furnaces**





**Henan Qianjin Heavy Industry Casting and Forging Co. LTD**

## **Rotary shot blasting chamber**





**Henan Qianjin Heavy Industry Casting and Forging Co. LTD**

## **93 Ton slag tank casting**





Henan Qianjin Heavy Industry Casting and Forging Co. LTD

## Grinding Machine

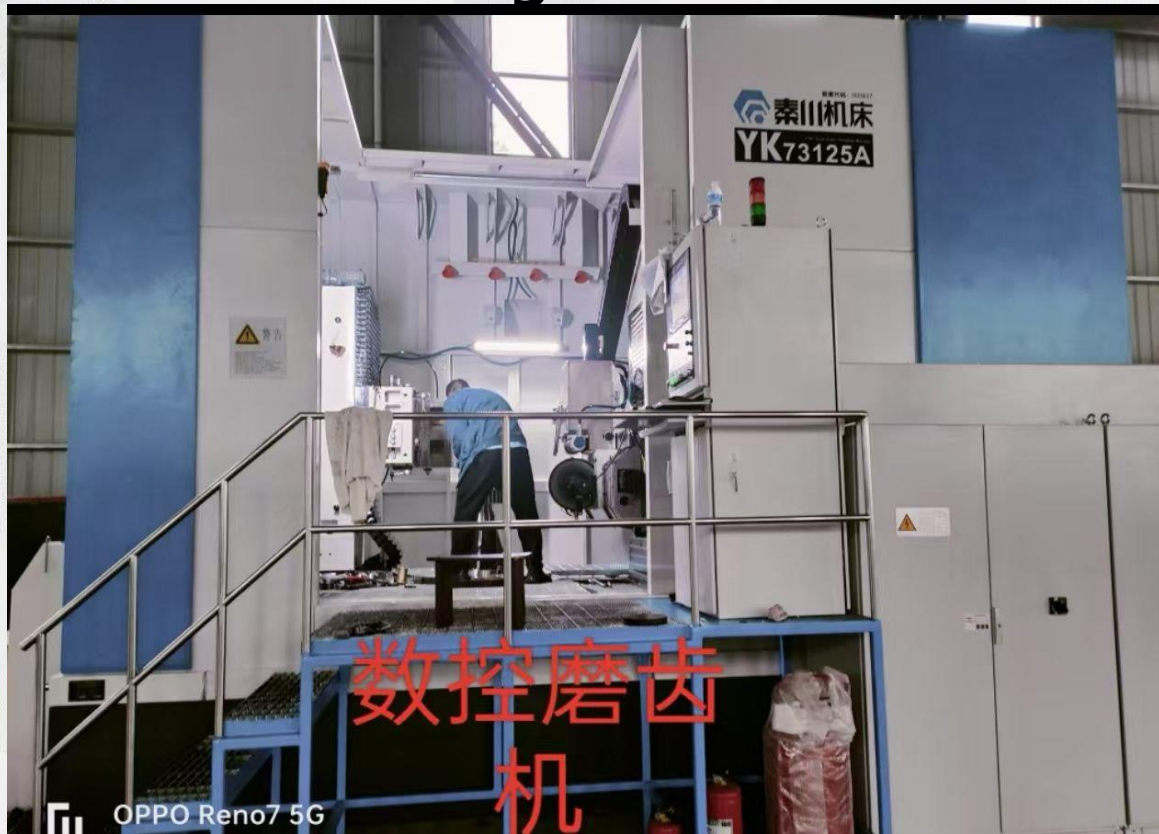



**Henan Qianjin Heavy Industry Casting and Forging Co. LTD**

## **Hobbing Machine**

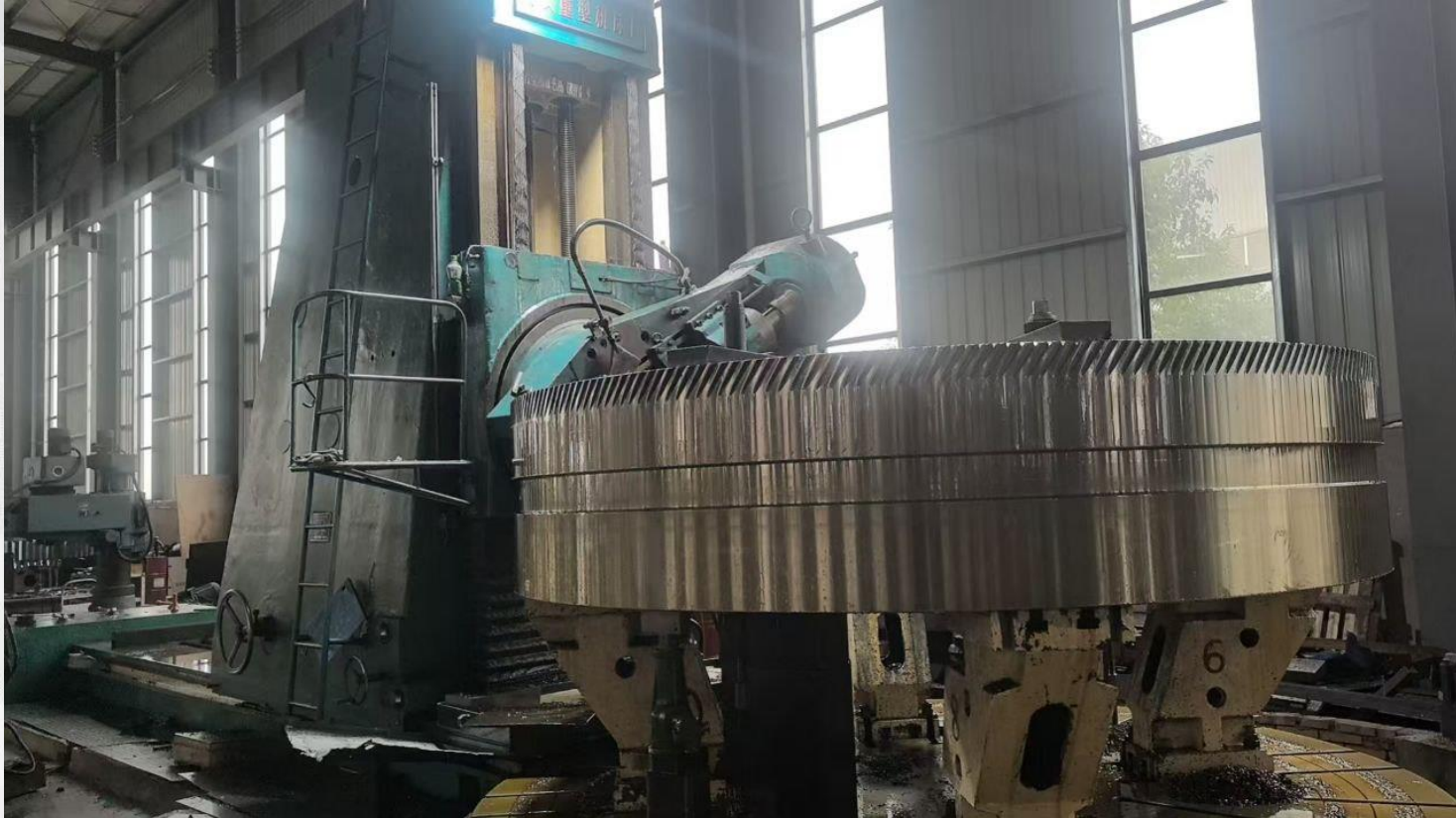



**Henan Qianjin Heavy Industry Casting and Forging Co. LTD**

## **Hobbing Machine**





**Henan Qianjin Heavy Industry Casting and Forging Co. LTD**

## **Rough Machining**





Henan Qianjin Heavy Industry Casting and Forging Co. LTD

## Forging





Henan Qianjin Heavy Industry Casting and Forging Co. LTD

## CNC Boring & Milling Machine



TK6920数控落地镗铣床  
CNC Boring and Milling Machine



# Henan Qianjin Heavy Industry Casting and Forging Co. LTD

**spectrum**



**Ultrasonic flaw detection equipment**



**60 tons tensile testing machine**



**Richter hardness tester**

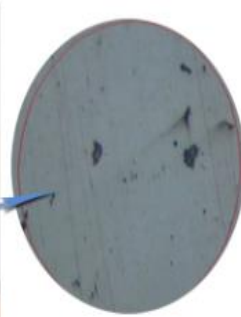

**Metallographic microscope**



**Magnetic particle flaw detector**



# Production Process and Simulation

## FEM Simulation

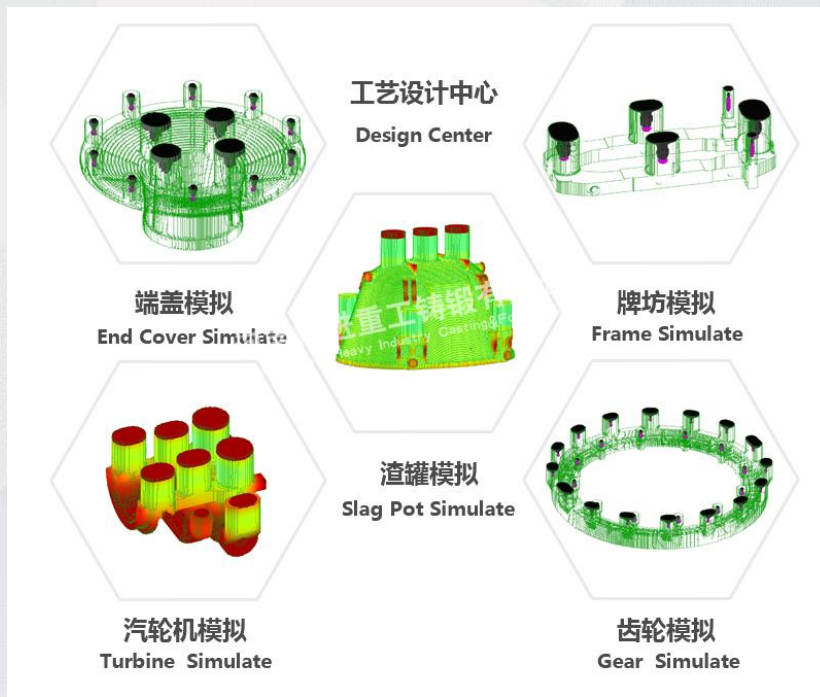





# Henan Qianjin Heavy Industry Casting and Forging Co. LTD

Belting leather

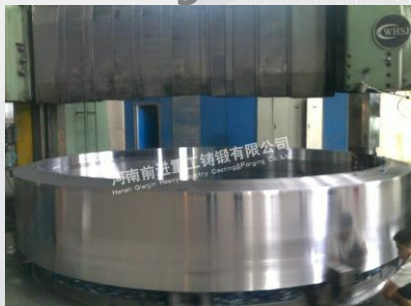

Rack



Cable Saddle



Tug



Bearing



Turbine block



Pull Rod



# Part of slag tank Reference List

Year	Customer	Size(Ton)	Material	Qty	Total
2021	GVA (Germany)	64.5	QJX-01	2	129
		19.175	QJX-01	3	57.525
		31.78	QJX-01	1	31.78
		39	QJX-01	16	624
		35.325	QJX-01	3	105.975
		59.1	QJX-01	2	118.2
		51.5	QJX-01	2	103
		32.2	QJX-01	2	64.4
		29.28	QJX-01	4	117.12
		26.5	QJX-01	2	53
		30	QJX-01	2	60
		19.65	QJX-01	2	39.3
		34.1	QJX-01	2	68.2
		31.9	QJX-01	1	31.9
		23.58	QJX-01	3	70.74
		32.18	ASTM A27 GR65-35	6	193.08
		62.76	QJX-01	1	62.76
		23.55	GS16Mn5	1	23.55
		29.91	QJX-01	2	59.82
		26.5	QJX-01	1	26.5
	29.8	QJX-01	2	59.6	
	42.95	QJX-01	1	42.95	
	36.2	QJX-01	4	144.8	
	32.17	QJX-01	5	160.85	
	Canada	24	ASTM A27 Gr70-36	1	24
	JSW	64.5	GS16Mn5	2	129
		28.5	GS16Mn5	4	114
	METAL MASTER (Mexico)	30.1	ASTM A27 GR70-40	2	60.2
	Vietnam	53	ZG230-450	2	106
	CSC	51	SCW450	5	255
	HYUNDAI	34	QJX-01	1	34
	POSCO	57.353	SC410	4	229.412
	KRAKATAU POSCO	57.4	SC410	3	172.2
	HYUNDAI	15.6	GS16Mn5	3	46.8
	Huanyoung Steel	25.8	QJX-01	3	77.4
	★AICHI STEEL	21	SCW450	2	42
★NSSMC	12.5	SCW410	1	12.5	

Year	Customer	Size (Ton)	Material	Q'ty	Total	
2022	GVA (Germany)	59.1	QJX-01	2	118.2	
		29.14	QJX-01	6	174.84	
		39	QJX-01	1	39	
		58.5	QJX-01	2	117	
		23.55	QJX-01	2	47.1	
		30.86	QJX-01	2	61.72	
		30.6	QJX-01	1	30.6	
		29.35	QJX-01	2	58.7	
		29.235	QJX-01	2	58.47	
		28.76	QJX-01	2	57.52	
		23.3	QJX-01	3	69.9	
		31.9	QJX-01	1	31.9	
		34.1	QJX-01	2	68.2	
		54.3	QJX-01	10	543	
		30	QJX-01	4	120	
		HYUNDAI	22	QJX-01	1	22
		POSCO	57.353	SC410	4	229.412
			72.6	SC410	6	435.6
	DOONKUK STEEL	15.6	GS16Mn5	2	31.2	
	Japan	22	SCW410	2	44	
		12.5	SCW410	1	12.5	
		9.9	SC450	3	29.7	
	INDIA	18.05	SCW410	10	180.5	
		64.5	GS16Mn5	5	322.5	
	METAL MASTER (Mexico)	43.8	GS16Mn5	5	219	
		30.1	ASTM A27 GR70-40	2	60.2	
	14.8	ASTM A27 GR70-40	2	29.6		



**Henan Qianjin Heavy Industry Casting and Forging Co. LTD**

## **Slag tank FEM Simulation**

Through strict technological measures and production management, product quality, The volume reached the height of users recognition

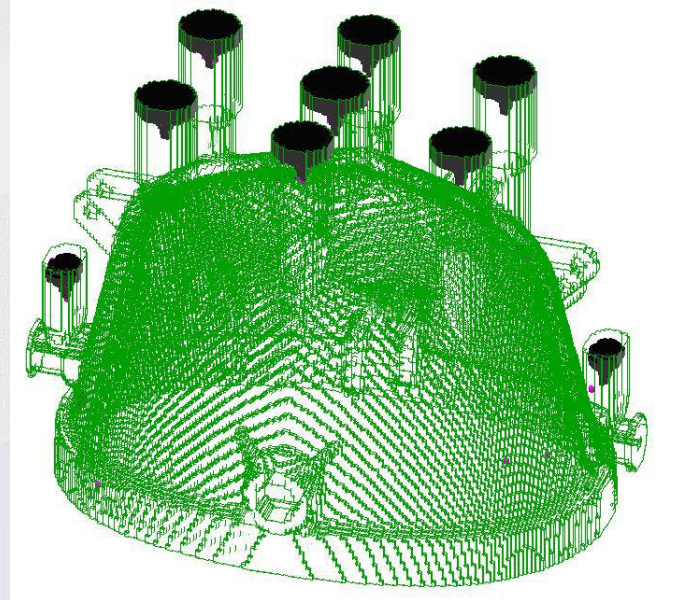
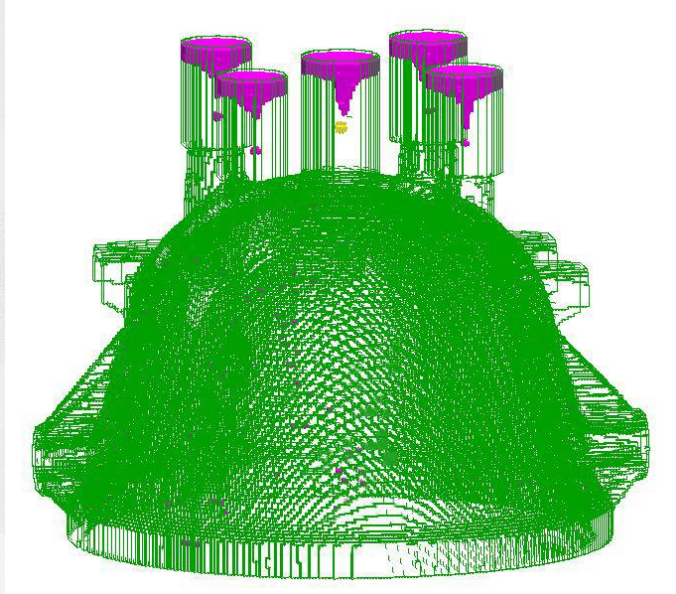



# Henan Qianjin Heavy Industry Casting and Forging Co. LTD

## Flow chart of slag ladle production



Wooden mold



SCULPT



Pouring



Finish grinding



Sand cleaning



Heat preservation



Flaw detection



Finished product



Delivery of goods



# Slag tank product display





# Backup Roller Production

---



**Backup Roller Pre-Inspection**



# Backup Roller Production

---



## Backup Roller Forging



## Backup Roller Machining



# Backup Roller Production

F: Transient Thermal  
Temperature  
Type: Temperature  
Unit: °C  
Time: 2866,9  
04.02.2017 18:29

930 Max  
831,95  
733,91  
635,86  
537,81  
439,76  
341,71  
243,67  
145,62  
47,572 Min

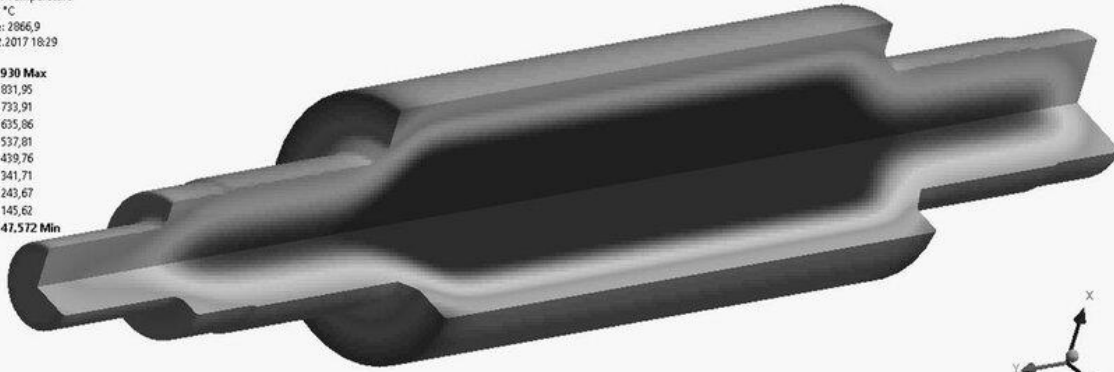

## Backup Roller FEM Simulation and Transportation





# Backup Roller Reference List

**Product performance table of support roll of large medium**

Product application	material	weight (T)	Embryo weight (T)	specification (mm)	Steel ingot(T)	quantity	Year of production
MCC Jingcheng 3800mm wide and thick plate mill support roll (spare roll)	45Cr4NiMoV	143.746	183.58	φ2220×4330×9480	273	4	2015
Jiangyin Xingcheng 3500mm coiling mill support roll (Spare volume)	45Cr4NiMoV	115.250	148.36	φ2055×3890×8640	226	2	2017
Nanyang Hanye 2800mm plate mill support roll (spare roll)	45Cr4NiMoV	79.950	102.32	φ1895×2955×7365	165	2	2018
Nanyang Hanye 3500mm plate mill support roll (spare roll)	45Cr4NiMoV	115.467	147.92	φ2055×3890×8600	234	2	2018
Nanyang Hanye 3800mm plate mill support roll (spare roll)	45Cr4NiMoV	154.2	199.67	φ2320×4125×9875	300	1	2021
MCC Jingcheng 3800mm wide and thick plate roughing mill (spare coil)	45Cr4NiMoV	153.383	196.14	φ2320×4260×9410	300	10	2023-2024
MCC Jingcheng 3800mm wide and thick plate roughing mill (spare coil)	45Cr4NiMoV	258.800	318.44	φ2520×6045×11925	483	3	2023
Nanyang Hanye 3500mm wide and thick plate support roll (spare roll)	45Cr4NiMoV	115.47	146.42	φ2055×3890×8600	228	2	2024



# Gears and Pinions





# Gears and Pinions Reference List

Gear ring performance sheet			
Customer name	The year 2021/Ton	The year 2022/Ton	The year 2023/Ton
Jinan Heavy Industry	200	240	300
North Heavy Industry	150	160	190
Citic Heavy Industries	100	155	210
Shen Ye reload	170	210	225
Zhejiang Tongli	210	185	170
Jiang Su Pengfei	220	190	168
China Building Materials Tangshan branch	150	120	175
Metso Altut	180	220	230
Haining NAT Import and Export Co., LTD	80	120	165



# Turbine cylinder block

---

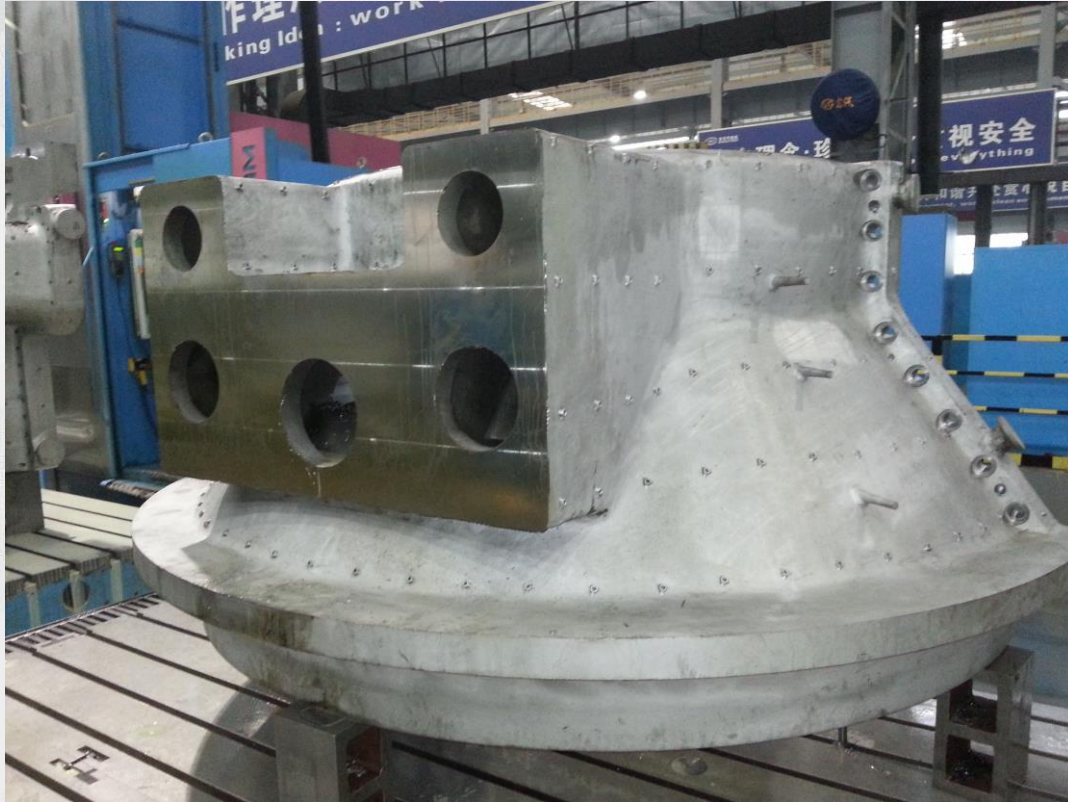



# Tire Belts

---

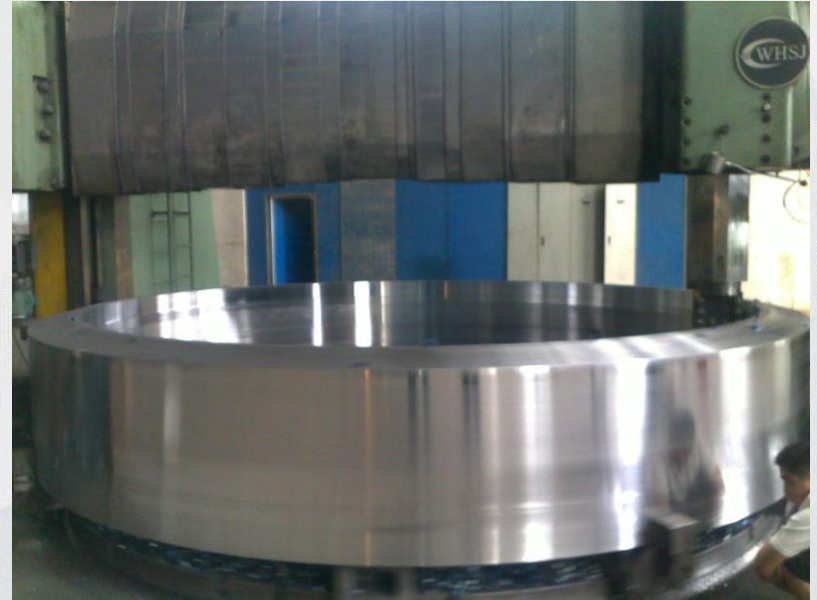



# Mill End Cover and Headwall

---

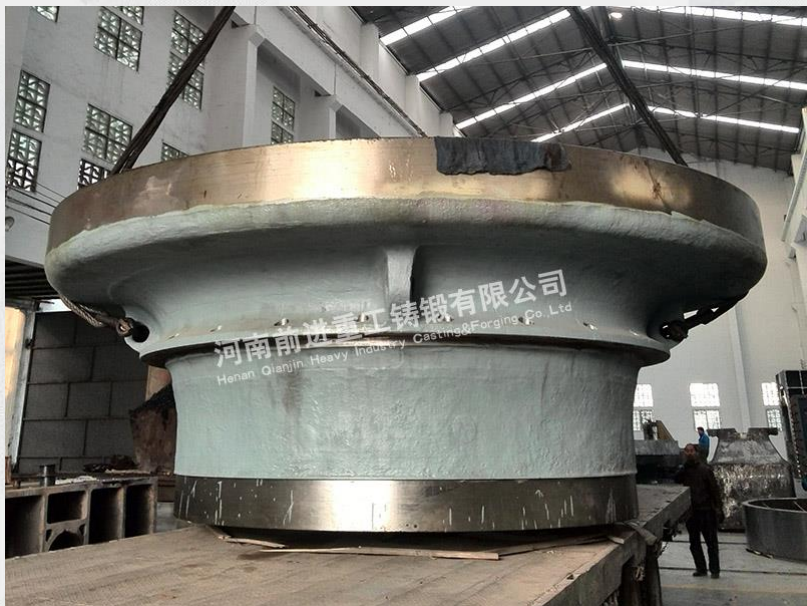



# Mill End Cover and Headwall

---



**Shargh White Cement  
Headwall Inspection**





# Mill End Cover and Headwall Reference List

	company	area	quantity	tons
2022	GZFB	China	19	578.3
	DZYL	China	2	114
	ZZYL	China	14	588.6
	ZZYS	China	2	171.2
	Via Trader	Germany	4	256.8
	Via Trader	Japan	13	81.3
	Via Trader	Russia	6	195.8
	Via Trader	Korea	2	38.7
2023	company	area	quantity	tons
	GZFB	China	22	647.8
	DZYL	China	6	312.8
	ZZYL	China	22	756.2
	ZZYS	China	5	426.3
	Via Trader	Germany	10	189.7
	Via Trader	Japan	6	101.5
	Via Trader	Russia	4	165.4





# Rollers



**Sepehan Cement Kiln  
Roller Rough Machining**

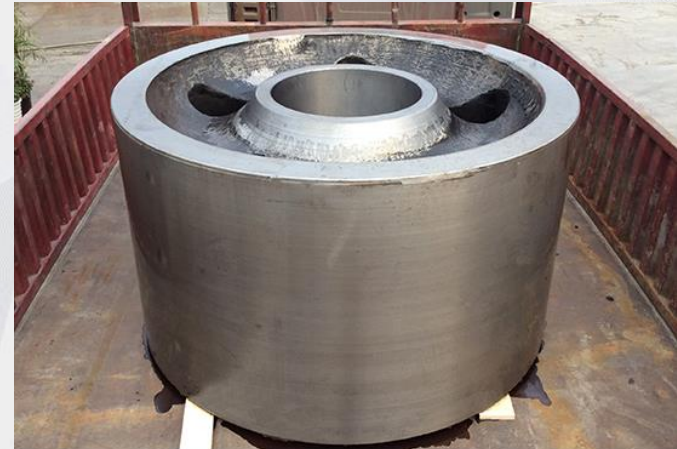



# Rollers and Shafts

---



**Sepahan Cement Kiln  
Roller and shaft**



# Rollers and Shafts



**Sepahan Cement Kiln  
Roller and shaft  
Transportation**



# Cement Industry Reference List

## Cement mine product performance statement

Customer name	The year 2021/Ton	The year 2022/Ton	The year 2023/Ton
Jinan Heavy Industry	700	900	1100
North Heavy Industry	600	700	850
Citic Heavy Industries	600	800	920
沈冶重装	200	300	490
Zhejiang Tongli	500	700	880
Jiang Su Pengfei	400	500	670
China Building Materials Tangshan branch	300	400	560
Metso	300	400	560
Haining NAT Import and Export Co., LTD	350	420	600



# Trunnion product display

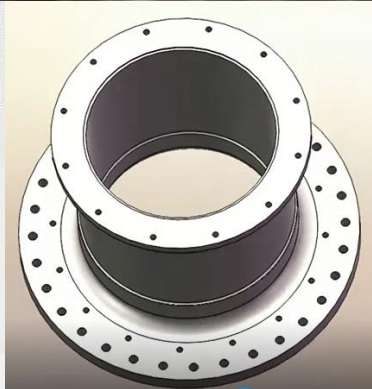
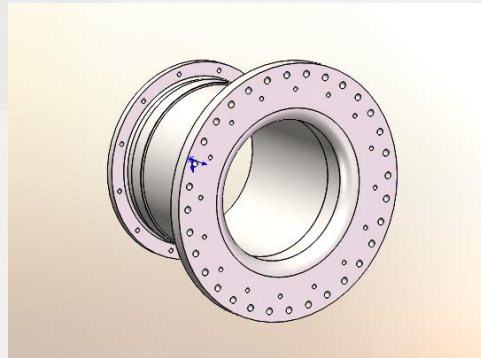



# Product Transportation





**thank you**

Henan Qianjin Heavy Industry  
Casting and Forging Co. LTD

Allen•GUO: +8617698227220  
EMIL:qianjinzhonggong@163.com